

J. O. COUCH.
Clothes-Wringing Machines.

No. 149,200.

Patented March 31, 1874.

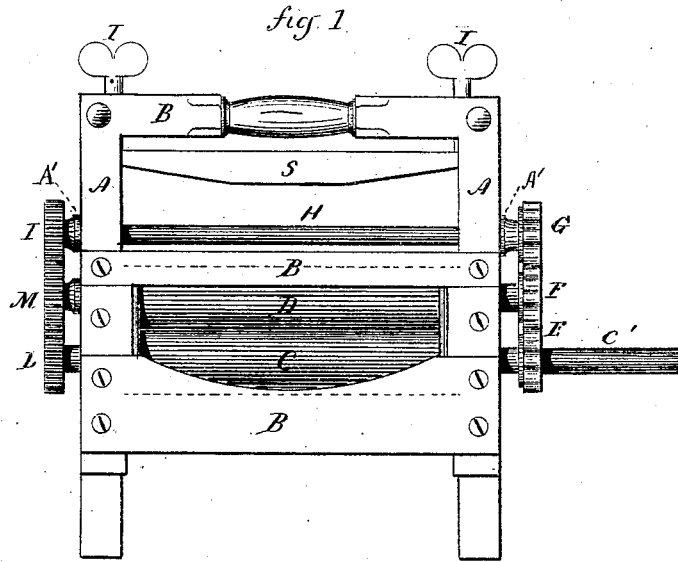

fig. 1

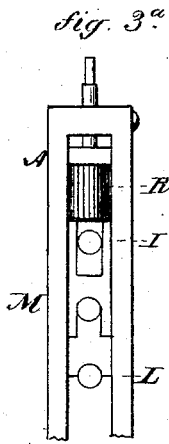

fig. 3^a

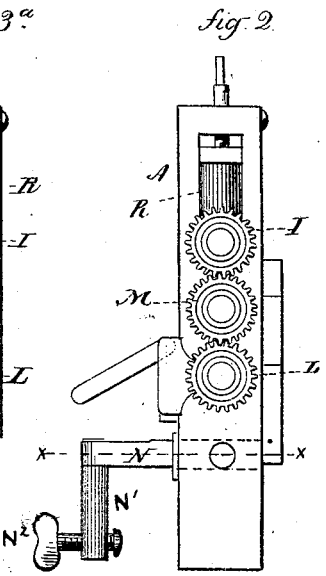

fig. 2

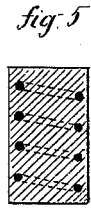

fig. 5

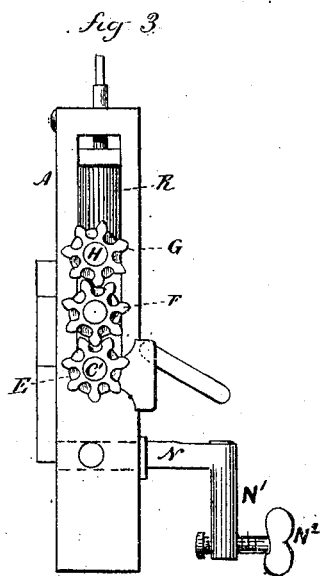

fig. 3

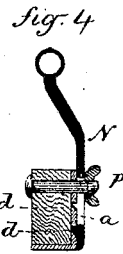

fig. 4

Witnesses.
W. H. Sumner
A. J. Tibbitts

John O. Couch
 Inventor.
 By Atty.
John E. Earle

UNITED STATES PATENT OFFICE.

JOHN O. COUCH, OF MIDDLEFIELD, CONNECTICUT.

IMPROVEMENT IN CLOTHES-WRINGING MACHINES.

Specification forming part of Letters Patent No. **149,200**, dated March 31, 1874; application filed May 23, 1873.

To all whom it may concern:

Be it known that I, JOHN O. COUCH, of Middlefield, in the county of Middlesex and State of Connecticut, have invented a new Improvement in Wringers; and I do hereby declare the following, when taken in connection with the accompanying drawings and the letters of reference marked thereon, to be a full, clear, and exact description of the same, and which said drawings constitute part of this specification, and represent, in—

Figure 1, a front view; Fig. 2, a left-hand end view; Fig. 3, a right-hand end view. Fig. 3^a is an end elevation corresponding to Fig. 3, but with the gear-wheels removed to show the provisions by which the action of the spring is communicated to the upper roller, leaving the counter-shaft unaffected. The counter-shaft, it will be understood, is supported in fixed bearings bolted upon the fixed framing; Fig. 4, a transverse section on line *x x*; and in Fig. 5, a section of one of the upright springs.

Similar letters of reference indicate like parts in all the figures.

My improved wringer has two elastic rolls, one of which is movable toward and from the other, with peculiar mechanism for imparting the required rotatory motion to the movable roll.

Referring to the drawings, which represent what I consider the best means of carrying out the entire invention, A A are the two posts; B B B, the cross-bars; C, the lower roll; D, the upper roll, of substantially the usual form and construction. The lower roll is driven by the application of power to its shaft C', and, when only a small thickness of clothes is being passed through, a pinion, E, on the said shaft communicates the power to the upper roll through the pinion F on the said roll, also in the usual manner. The roll D is made self-adjusting, so as to rise and fall, while the lower roll C runs in stationary bearings, and the pinions E and F are constructed so as to allow the usual amount of such movement to the roll D. When the roll D has been raised so far as to throw the gears E and F out of contact, the movement of that roll must depend upon other forces. In order to make a constant driving-power to work upon the

roll D, I arrange a third pinion, G, at a suitable distance above, (here shown as upon a counter-shaft, H, which runs across the frame;) and upon the opposite end I arrange a pinion, I, and a corresponding pinion, L, upon the corresponding end of the shaft C', and between these I mount a pinion, M, upon a stud made stationary upon the frame, so that the turning of the shaft C' will cause a corresponding revolution of the shaft H. When the roll D, with its attached gear-wheel F, rises so far that F is nearly out of gear with the pinion E, then it properly engages with pinion G, and receives therefrom its revolution in the same direction as before. This mechanism greatly increases the range of adjustment of the roll D over the usual construction.

While I prefer to arrange the chain of gears L M I upon the opposite side of the machine, as described, the same result may be attained by applying them at the same side, or at other convenient point, it only being essential that the power be communicated by some means to the pinion G, so that the pinion F may be operated by either E or G, according to its relative position, as before described.

N N¹ is the clamp-arm, one of which is applied to each post A; and upon the post a plate, *a*, is arranged, with notches *d* formed therein. The arm N N¹ has a projection, *n*, upon its surface, so as to lock into one or another of the said notches. A pinching-screw, P, is applied through the said arm, by means of which to secure it upon the framing.

To adjust the machine to match on thicker or thinner tubs, set the projection *n* of the arm N N¹ into the notch *d* nearest the desired point, and tighten the screw P; then the clamping-screw N² is turned in the usual manner, and may be a comparatively short screw.

R is one of my peculiar vertical springs, applied to each end, and upon which I preferably arrange a cross-bar, S, upon which the adjusting-screws T bear in substantially the usual manner, these springs resting upon the bearings of the movable roll D through suitable intervening slide-boxes. The shaft H is supported by cross-bridges A', and the slide-boxes are forked, so as to move freely past as the roll D moves up and down. These springs I construct from a suitable elastic wire wound

into spiral form; then the spring is set into a mold, and india-rubber or similar gum placed upon the spring, so as to completely inclose the wire, as seen in section, Fig. 5. This is more durable than when the wire is simply coiled around the rubber.

I claim—

In a clothes-wringer, substantially as described, the movable roller D and gear-wheel F thereon, in combination with gear-wheels E

and G, arranged upon shafts running in fixed bearings above and below such gear-wheel F, respectively, as set forth, so that such gear, as it rises and sinks, will engage alternately with gear-wheels E and G, as specified.

JNO. O. COUCH.

Witnesses:

A. J. TIBBITS,

J. H. SHUMWAY.